

MINUTEMAN

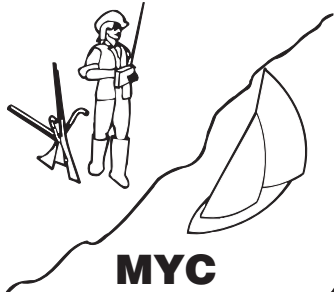

Minuteman Model Yacht Club

Commodore: Hal Robinson, 19 Orlando Avenue, Arlington, MA 02474-2922 (781) 648-4074

Vice Commodore: Art Jacobsen, 43 Cedar Street, Foxborough, MA 02035 (508) 543-1321

Harbor Master: Ben Pratt, 131 Windermere Rd., Newton, MA 02466 (617) 965-0377

Secretary/Treasurer: Jack Sullivan, 33 Rustic Road, E. Walpole, MA 02032 (508) 668-7163

AMYA President: Jack Gregory, 131 N. Main Street, Sharon, MA 02067-1227 (781) 784-7625

AMYA Region 1 Director: Peter Latournes, 10 Acorn Dr, Windsor Locks, CT 06096 (860) 623-1710

Newsletter Publisher/Editor: Jim Linville, 57 Edgewater Road, Hull, MA 02045 (781) 925-0045

FEBRUARY 2001

About Minuteman Model Yacht Club

The Minuteman MYC is dedicated to the development of all aspects of model sailing. Dues for the year 2001 are \$15.00; checks should be made out to "Minuteman MYC" and sent to Jack Sullivan at the address above.

Formal trophy regattas are held regularly. From April to June. Informal sailing sessions are held on Tuesday evenings between 3:00 PM and Sunset, and on Sundays beginning at 11 AM at Needham Reservoir, and at Rosemary Lake in Needham until November. Indoor meetings are held monthly between January and March.

The club recommends that new members select the Soling One Meter class yacht as their first boat. The Soling One Meter is a low-cost, entry-level, one-design boat. It is available in kit form, and a complete, ready to sail yacht can be built for less than \$250, including radio.

If you have questions, don't hesitate to call any of the officers listed above. Or come and see us on Tuesday evening or at one of our regattas. Also, check out the AMYA web page on the Internet <www.amya.org>.



MMYC Commodore, Hal Robinson's, "Q-Boat" being sailed by the editor in the San Diego Model Yacht Basin. It is not overtaking a Marblehead in light winds.

Tech Tuesdays

By Jim Linville

If you haven't noticed, this is the second month in a row that the newsletter has been mailed from Arizona where your intrepid editor has escaped to avoid more pressing and uncomfortable responsibilities at home. I have to admit that it's really nice to soak up sun while watching weather reports about snow, sleet, and below zero temps. I can even revel in the fact that my thermostats at home are turned as low as possible (just high enough to keep the pipes from freezing), and that my gas bill was less than \$200 for the first December since I switched from oil. Who knows, maybe there's some "Snowbirding" in my future.

If the truth be known, the thing I miss most about New England in the winter is Tech Tuesdays at Hal's. There are a lot of fine people and excellent sailors out here, but none of them are crazy enough to seriously suggest building an inflatable USIM in order to

(Continued on page 2)

IN THIS ISSUE:

- ⇒ Tech Tuesdays
- ⇒ Meeting Report
- ⇒ Region One Schedule
- ⇒ Rules for Club Metric Series
- ⇒ Fin Trunks

Copyright © 2001 by Minuteman Model Yacht Club. The materials herein can be used in other club newsletters provided the source is clearly identified. Portions of the content are available via e-mail from Jim or Sue Linville at jimisu@mediaone.net. The Minuteman Model Yacht Club is club number 25 of the American Model Yachting Association (AMYA). This newsletter is sent to all official AMYA club contacts in AMYA's Region 1. Those contacts should try to ensure that any pertinent information is passed along to their club members at the next opportunity. Send address changes to Jack Sullivan and editorial material to Jim Linville at the addresses above. The deadline for submission of editorial material is the 21st day of the month prior to publication. Materials received after the 21st day will be published in the following month, space permitting.

cut down on weight. Think about it, where else but at Hal's could that happen.

If you haven't dropped by Hal's on Tech Tuesday you don't know what you're missing. The next Tech Tuesday will be held on February 20th. Doors open at 2 PM, and we'll order out food if we want. Mark your calendar and plan to attend. You won't be sorry. Everyone is invited. Emphasis is on helping newcomers build and get their boats ready for the new season, but you can bet there will be plenty going on to interest any experienced skipper.

For those who don't remember, Hal lives at 19 Orlando Avenue in Arlington, MA. The phone number is (781) 648-4074. To get to Hal's: Take Route 128 to Route 2. East on Route 2 towards Boston for approximately 5 miles to Route 60 (Exit 59). Turn left on Route 60 for approximately 1 mile to Massachusetts Avenue. Left on Mass Avenue 2 - 3 blocks to Mill Street. Right on Mill Street 1-1/2 blocks to Summer Street. Left on Summer Street two short blocks to Richfield Road. Up the hill half a block or so to the first intersection. Sharp turn to the right onto Orlando Avenue Number 19 is at the top of the hill on the right.



Next Meeting to Feature Boat Construction

Minuteman Model Yacht Club's next indoor meeting will be held at the Massachusetts Hospital School in Canton, MA on Sunday, February 11th. Please mark your Calendars and plan to attend.

Our indoor meetings are a chance to keep in touch with your fellow skippers, exchange information, drink bad coffee, and show off winter projects. This is our second indoor meeting of the year. It is devoted to boat construction, and its main purposes are to exchange ideas and help newcomers get a clean start. Please bring your latest projects. The third meeting (second Sunday in March) is when we discuss the new racing rules. Meetings start at 1 PM, but the doors open at Noon, and there's always time to discuss your projects.

Club Business

by Jack Sullivan

Minuteman Model Yacht Club's first indoor meeting of 2001 was held at the Massachusetts Hospital School on Sunday, January 14th. It was a cloudy but pleasant day. Hospital School Security asked that we use the meeting room in the gymnasium building and that we enter the building *via* the elevator. Since many of the MMYC members attending the meeting didn't know the school had an elevator, let alone where it was, the first obstacle of the day was finding our way into the meeting room. With a trail of paper signs and a couple of skippers in the parking lot giving directions we all found our way inside.

The water was hot for instant coffee and tea. There was plenty of homemade cake and cookies (courtesy of Joan Sullivan). There was even some leftover Christmas candy. The goodies were ready and being consumed before Commodore, Hal Robinson, called the meeting to order at 1:00 PM.

Monetary Matters

The first item on the agenda was the Treasurer's report. In summary, the club has adequate funds to conduct its normal business for the year, and copies of the Treasurer's report will be available to MMYC members at the next meeting.

We discussed doing away with trophies, but decided not to because the income from skipper's registration fees balances our expenses for trophies, so they create very little budgetary impact. We also approved renewing the AMYA Pond Owners Insurance, which we purchase for the Town of Needham.

Club Management

Next we discussed club management. A new position (to be called Harbor Master) was proposed and approved. The duties of the Harbor Master will be to anticipate on-the-water needs for upcoming regattas (such as chase boats and buoy placement). This will give one person the responsibility for such things as knowing who is going to be available to go out in the chase boat and which chase boat is to be used. More tasks will be found for this person as the season gets going. Ben Pratt (not present at the meeting) has volunteered for the position. The Harbor Master will replace the Rear Commodore on the masthead.

There were no other nominees for any other position, so the Club Secretary was instructed to cast a single ballot to re-elect the existing slate with the modifications described above. Your club officers for 2001 are: Hal Robinson, Commodore; Art Jacobsen, Vice Commodore; Ben Pratt, Harbor Master; and Jack Sullivan, Secretary/Treasurer. Jim Linville, will continue as Newsletter Editor.

Outreach Programs

We also discussed the Massachusetts Hospital School indoor sailing program for kids confined to wheelchairs. The program is progressing well, and we don't think we need a great deal of financial help at present. We have 12 Victor Snipes and 3 English 575's in the indoor fleet.

What we need in this program is YOU. Bob Francis, Sally Smith, Andy Smith, and Jack Sullivan have been meeting with the kids for ten-plus years. There are times when one or two of us can't make it, and we could really use a couple more knowledgeable adults to help get the boats ready for the evening and put them away.

We then discussed our Veterans Administration Hospital program. Though we have sailed with the veterans on four occasions we still have the feeling we need a VA staff member to act as a spark plug.

Rosemary Lake

Hal gave a report on the waterfront at Rosemary Lake. The gist of Hal's report was that he and Jack Gregory will attend a meeting of the Town of Needham Planning Board later this month to discuss upgrades to the site.

(Continued on page 3)

Regatta Schedule

We then went over the regatta schedule for the year 2001. Jack Gregory marked up a copy of the schedule as it was received from AMYA Region 1 Director Peter Latournes. George Greenhalgh was present so we minimized conflicts between the EC-12, Soling One Meter and US One Meter classes. There are still a few minor corrections to make, but a *draft* schedule appears elsewhere in this issue.

This year's schedule provides for two distinct club series: the US One Meter series, and a new series for Soling One Meter class boats. The schedule alternates having days solely for each class with three combined regattas where both classes will sail with a 2-on, 2-off format so owners of both classes will be able to compete in both series.

Solings may sail in the US One Meter series (but with no headstart). The goal being to encourage sailing by all members,

and still bring meaningful competition to everyone.

One important modification to our standard procedure will be a positive point scoring system in which a skipper receives one point for each boat he/she beats in all of the regattas. The skipper with the highest score at the end of the season wins. Thus, it won't matter how many races are run, there is no "ghost" score, and those who cannot attend all events aren't completely out of reach. (See "Metric Series Rules" article elsewhere in this issue.)

We discussed and approved renaming the Trigg Memorial Regatta to the Sue Linville Memorial Regatta. This will be an open regatta, and if possible, we will work in an event for schooners and other scale craft on the same day. Sue really liked the schooners. The date for this regatta will be Labor Day, and proceeds will be donated to charity.

We had more topics to discuss, but ran out of time. The February meeting on the 11th will be a construction seminar with a number of discussion topics left over from the January meetings.

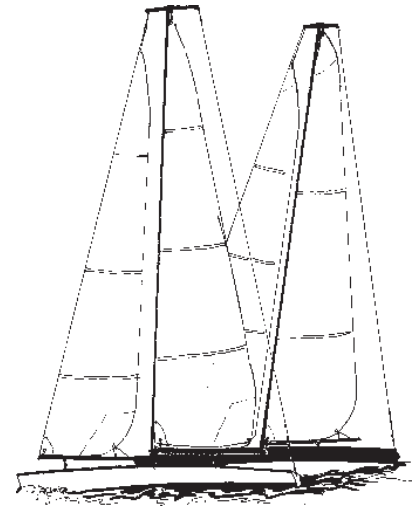

A Message from Your AMYA Region One Director

By Pete Latournes

Following is the tentative Region One Regatta Schedule for 2001. The schedule was put together after much discussion with the region's club contacts. For your convenience we have listed the National Championship Regattas that have been confirmed for the classes of yachts we sail in the region. You will also notice we will have one less Soling One Meter Interclub Race. Springfield Model Yacht Club has chosen not to participate in this year's series bringing the number of clubs vying for the championship from eight to seven.

I would like to thank all the club contacts for submitting their inputs in a timely fashion. To add a date or if you have any questions please contact me at 860-623-1710 or e-mail at platournes@aol.com.

New England Model Yachting Event Schedule for Year 2001

This list is as complete as possible. Events beginning with "Club" are local club events and may be restricted to members of the sponsoring club. Club names are:

- 020, Greater Hartford MYC, Rich Ellis, (860) 228-3327, <richard.ellis@snet.net>
- 025, Minuteman MYC, Art Jacobsen, (508) 543-1321, <Arthur.Jacobsen@world.att.net>
- 026, Penobscot Bay MYC, Dave Fuller, (207) 236-0241, <dflfuller@midcoast.com>
- 039, Mystic R/C Sailors, Jake Leo, (860) 536-8087, <jleo@connix.com>
- 040, Portsmouth MYC, Alain Jousse, (603) 433-1584, <alainj@mediaone.com>
- 041, Marblehead MYC, Standley Goodwin, (781) 631-5847, <sgoodwin@draper.com>
- 051, Narragansett MYA, George Greenhalgh, (401) 245-7493, <robbsky@aol.com>
- 083, Springfield MYC, Fran Gowash, (860) 749-4726, <frgowash@home.com or gowashfp@pweh.com>
- 117, Housatonic MYC, Tony Bosco, (203) 879-9211
- 130, Laconia MYC, Lee Donahue, (603) 293-7769 or

Joe San Antonio, (home) (603) 434-8505, (work) (978) 686-7131

- 159, Stowe YC, Charlie Berry, (802) 253-4184, <cberry@weblizard.net>
- 215, Martha's Vineyard MYC, Glenn Provost, (508) 693-4245, <gprovost@vineyard.net>
- Vin, Vintage Model Yacht Group, John Snow, (781) 631-4203, <JSnow@drc.com>

Other clubs exist, but have not submitted events for this calendar. To submit events, contact Peter Latournes at (860) 623-1710 or via e-mail at <platournes@aol.com>.

(Continued on page 4)

(Continued from page 3)

<i>Date</i>	<i>Event</i>	<i>Club</i>	<i>Class</i>	<i>Location</i>	<i>Time</i>
1/14	MMYC Meeting	025		MA Hospital School	12 noon
2/11	MMYC Meeting	025		MA Hospital School	12 noon
3/11	MMYC Meeting	025		MA Hospital School	12 noon
4/1	Ice Breaker	025	Open	Needham Reservoir, MA	10am
4/16 (Mon)	Patriot's Day Regatta	025	Open	Needham Reservoir, MA	10am
4/21	Woods Hole Open Regatta	025	Open	Eel Pond, Woods Hole, MA	10am
4/20-21	Woods Hole Boat Show	Vin	Exhibit	Woods Hole, MA	
4/29	Club US1M #1	025	US1M	Needham Reservoir, MA	10am
5/6	Spring Highball	051	EC12	Roger Williams St Pk, RI	10am
5/12 (Sat)	S1M interclub #1	020	S1M	Mansfield Hollow, CT	11am
5/20	Marblehead Reg. 1 Champ.	041	Marblehead	Redds Pond, MA	10am
5/20	Club US1M #2, S1M #1	025	US1M/S1M	Needham Reservoir, MA	10am
5/27	Club S1M #2	025	S1M	Needham Reservoir, MA	10am
6/2-3	Green Mountain Regatta	159	EC12	Stowe, VT	10am
6/10	Club US1M #3	025	US1M	Lake Rosemary, MA	10am
5/12 (Sat)	Full Cup	041	VM	Redds pond, MA	1pm
6/17	Club US1M #4, S1M #3	025	US1M/S1M	Lake Rosemary, MA	10am
6/22-24	Wooden Boat Show	Vin	Exhibit	South Haven, MI	
6/23-24	IOM Reg. 1 Championship	039	IOM	New London, CT	10am
6/24	914 Reg. 1 Championship	041	914	Redds Pond, MA	10am
6/30	Bacardi Cup (Interclub #2)	159	S1M	Stowe, VT	10am
7/4	Independence Day Regatta	025	Open	Lake Rosemary, MA	10am
7/8	Club S1M #4	025	S1M	Lake Rosemary, MA	10am
7/8	Tony Lombardi Open	051	Open	Roger Williams St Pk, RI	10am
7/15	S1M Reg 1 Championship (Interclub #3)	026	S1M	Hosmer Pond, ME	10am
7/22	Club US1M #5	025	US1M/S1M	Lake Rosemary, MA	10am
7/29	Bill Visser Mem (Interclub #4)	130	S1M	Lilly Pond, Laconia, NH	10am
8/3-5	J Reg. 1 Championship	041	J	Mystic Seaport, CT	
8/3-5	VMYG Schooner Regatta	Vin	Schooner	Mystic Seaport, CT	
8/4	Commodores Cup	159	S1M	Stowe, VT	10am
8/12	Marblehead Regatta	117	Marblehead	Housatonic, CT	10am
8/19	SSC Open Regatta	040	Open	Portsmouth, NH	10am
8/19	EC12 Region 1 Championship	051	EC12	Roger Williams St Pk, RI	10am
8/26	Hank Bouchard Memorial	051	EC12	Roger Williams St Pk, RI	10am
8/26	Club S1M #5	025	S1M	Lake Rosemary, MA	10am
9/3 (Mon)	Sue Linville Memorial	025	Open	Lake Rosemary, MA	10am
9/9	S1M Interclub # 5	040	S1M	Portsmouth, NH	10am
9/16	US1M Reg. 1 Championship	117	US1M	Housatonic, CT	10am
9/22-23	Star 45 National Championship		Star 45	Dayton, OH	
9/30	US1M Regatta	117	US1M	Housatonic, CT	10am
9/30	Campbell Cup Regatta	041	Marblehead	Redds Pond, MA	10am
9/30	Club Champ. Match Race	051	EC12	Roger Williams, St Pk, RI	10am
10/6-7	IOM National Championship	086	IOM	Mill Pond, NY	
10/7	Club Champ. Fleet Race	051	EC12	Roger Williams St Pk, RI	10am
10/5-8	S1M National Championship	019	S1M	Ashburn, VA	
4/16 (Mon)	Columbus Day Regatta	025	Open	Lake Rosemary, MA	10 am
10/13 (Sat)	S1M Interclub #6	215	S1M	Martha's Vineyard, MA	10am
10/14	Chowder Cup Regatta	041	Open	Redd's Pond, MA	10am
10/17-28	Marblehead National Champ.	171	Marblehead	Ft. Pierce, FL	
10/21	Club US1M #6, S1M #6	025	US1M/S1M	Lake Rosemary, MA	10am
11/4	S1M Interclub #7	025	S1M	Lake Rosemary, MA	10am
11/11	Four Hour Enduro	025	Open	Lake Rosemary, MA	10am

2001 Club Metric Series Rules

by Jim Linville

After much discussion at the January meeting, the following set of rules have been adopted for the 2001 Club Metric Series.

Year 2001 Club Metric Series Rules

1. Twelve regattas are scheduled in the series — six for US One Meter Yachts and six for Soling One Meter Yachts. Three events will be combined regattas where both classes will sail in a 2-on, 2-off format so skippers who have registered in both classes can compete in both series.
2. The US One Meter series is restricted to yachts that can be registered in the US One Meter class, including 36/600s and International One Meters.
3. Members of other clubs are welcome to sail with us, but only the scores of Minuteman MYC members will be counted in the final tally.
4. The entry fee is \$5 for each series. That is, a single \$5 fee for all six regattas in each series (\$10 if you sail in both).
5. Following the final regatta of the series, "Keeper" trophies will be awarded to the top three finishers in each series. The winner of each series will have his/her name added to the perpetual trophy, and will be allowed to hold the perpetual trophy until someone else wins it.
6. The object is to sail as many heats as possible between 10 AM and 2 PM with a 30 minute lunch break. While more heats may be sailed on any particular day, only the first 13 heats will be recorded. There are no throwouts. A skipper's score is cumulative for the entire series and will simply be the total of the number of boats each skipper finishes ahead of — over the entire series.
7. The winner of each regatta must serve as (or provide) the Race Director for the next regatta in the series. Doctor's notes are accepted.
8. No heat may start without a designated score keeper. Hopefully, a nonparticipant will be available to serve as score keeper, but in the event no nonparticipating score keeper is on hand, the score keeping duties shall be rotated among participating skippers. If there are more skippers than heats those skippers who were not required to serve as score keeper shall sit out a heat (or heats) so that the number of heats sailed by all skippers in any particular regatta is equal.
9. The Race Director may sail in a heat, but the score keeper may not.
10. These rules are subject to change by vote of the majority of MMYC participants, but any change so voted shall not take effect until the next regatta in the series.

FULL HEIGHT FIN TRUNK

Reprinted from the *US One Meter Construction Guide*

The full height fin trunk serves a dual purpose, it secures the fin to the hull and acts as a mast support.

The trunk fits between the king plank and inner keel. The trunk sides and fin tongue are made from Birch 4 ply aircraft plywood. Make the fin tongue and stub from one piece of plywood. The trunk must be a good snug fit on the fin tongue.

Locate and cut a slot through both the inner and outer keel planks. Glue the trunk in the hull with epoxy or micro-balloons and Zap. Build a fillet around the joints. These joints bear heavy stresses and must be absolutely water tight.

Insert the fin tongue through the slot in the keel, push up until shoulder is snug against hull bottom

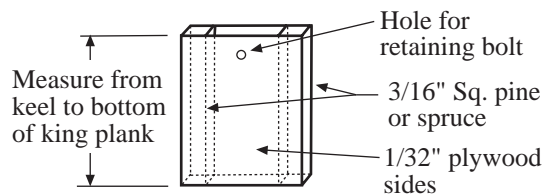

A small bolt and wing nut hold the fin in place.

Waterproof fin, and trunk both inside and out.

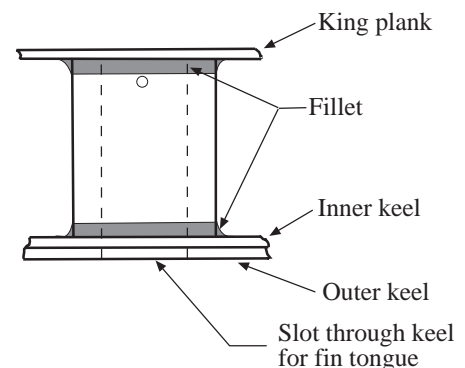

Directions to the Mass. Hospital School

The school is relatively easy to get to. Finding the meeting room at the school is a little harder.

From Route 128 take Route 138 South ("Stoughton"). Take a right on Randolph Street (second traffic light). Follow Randolph approximately 3/4 of a mile. The school is on the left. Enter through the guard house and drive *all the way* around the campus to the last parking lot before the exit gate (usually closed). You should see the MMYC sailboat sign or some other clue there.

We meet in the gymnasium meeting room. Enter via the elevator. Doors open at 12:00 noon and you are welcome to come early and stay late.

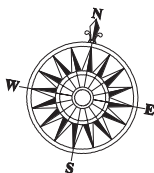
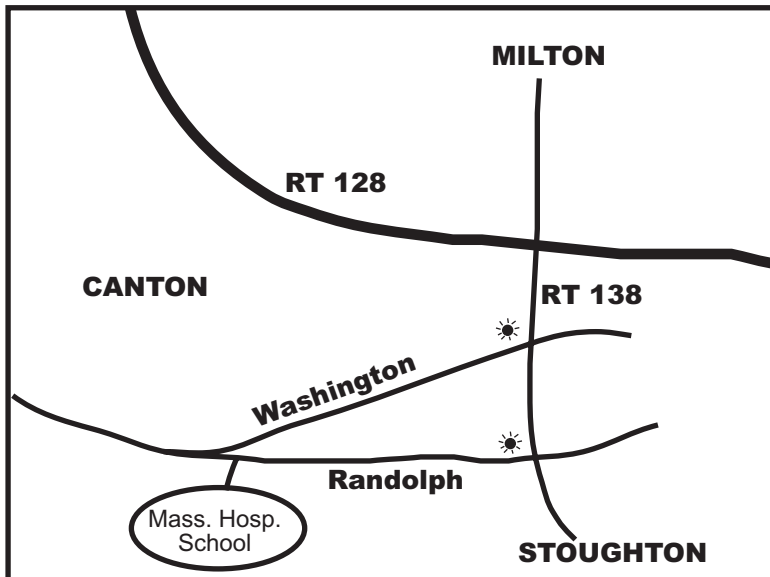

Minuteman Model Yacht club
 c/o Needham Park and Recreation
 Town Hall, Needham, MA 02192

